

Stage Chain Hoist

YUANTAI CRANE

YT-HGA D8 CLASSICAL MODEL

ADVANTAGE

BGV-D8 Standard and approved by CE / TUV Certificates.

Inside safe mechanical Brake Clutch

Wi compact upper limiter is available

Special alloy steel Load chain sprocket

New design side-out chain structure prevents stuck.

Mechanical brake and electromagnetic brake

EN 818-7 standard G80 chain

Aluminum alloy stretching shell with unique cooling function

High-strength aluminum alloy Gear Box



YT-HGA8 D8

220V-440V 3 Phase



Leading the entertainment industry for more than one decade, Yantai Crane offers best-in-class performance, safety and reliability. The YT Hoist is universally trusted by rigging professionals around the world and is ideal for touring concerts and productions both indoors and outside.

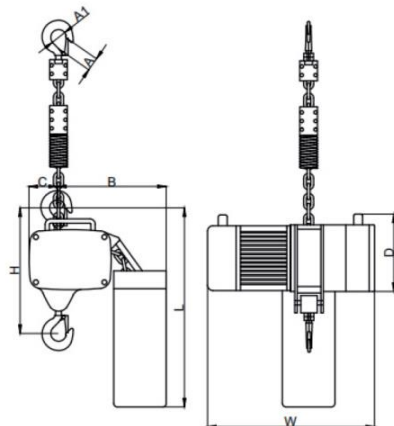

Specifications	
SWL acc. DGUV V54 (D8)	500Kg/1000Kg/2000Kg
Power supply	220-440V 3Phase 50/60Hz
Cable	1m Cable with CEE-16/4
Chain	EN818-7
Dynamic safety factor for chain	min. 8:1
Grade of steel	80
Chain surface	galvanized
Chain Guide	Precise chain guide with 5-pocket chain wheel
Clutch	Patented friction clutch for overload protection
Full load noise level(db)	≤65
Brake	Paramagnetic brakex1
Load hook	1-fall / tumble
Suspension	suspension hook
Mounting position	climbing & stationary
Plastic handles	without
Protection level	IP 55
Mechanism class /FEM9.511	1Bm/ 25% ED
Color	black, RAL9005 matt

Capacity	Chain Fall	Speed (m/min)	Power (kw)	Chain (mm)	Hoist Dimension(mm)						No Chain Self Weight (kg)	Chain Weight (Kg/m)	Flight Case	
					L	W	H	D	A	A1			Weight(Kg)	Size(mm)
HGA8-500KG	1	4	0.75	6.3*19	480	410	530	200	23	32	27	0.86	19.5	580*390*490
HGA8-1000KG	1	4	1.5	7.1*21	960	470	650	240	26	38	37.5	1.1	20	600*450*500
HGA8-2000KG	1	4	3.0	10*30	1200	630	800	280	33	47	76	2.0	21	680*450*650
HGA8-2000KG	2	2	1.5	7.1*21	960	470	750	240	32	47	37.5	2.2	19.5	680*450*650

YT-HGA9 D8

220V-440V 3 Phase

Leading the entertainment industry for more than one decade, Yuantai Crane offers best-in-class performance, safety and reliability. The YT Hoist is universally trusted by rigging professionals around the world and is ideal for touring concerts and productions both indoors and outside.

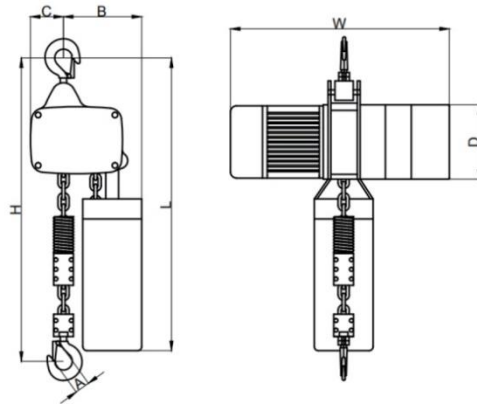

Specifications	
SWL acc. DGUV V54 (D8)	500Kg/1000Kg/2000Kg
Power supply	220-440V 1/3Phase 50/60Hz
Cable	1m Cable with CEE-16/4
Chain	EN818-7
Dynamic safety factor for chain	min. 8:1
Grade of steel	80
Chain surface	galvanized
Chain Guide	Precise chain guide with 5-pocket chain wheel
Clutch	Patented friction clutch for overload protection
Full load noise level(db)	≤65
Brake	Paramagnetic brakex1
Load hook	1-fall / tumble
Suspension	suspension hook
Mounting position	climbing & stationary
Plastic handles	without
Protection level	IP 55
Mechanism class /FEM9.511	1Bm/ 25% ED
Color	black, RAL9005 matt

Capacity	Chain Fall	Speed (m/min)	Power (kw)	Chain (mm)	Hoist Dimension(mm)						No Chain Self Weight (kg)	Chain Weight (Kg/m)	Flight Case	
					L	W	H	D	A	A1			Weight(Kg)	Size(mm)
HGA9-500KG	1	6.8	0.75	6.3*19	560	490	400	160	24	33	30	0.79	19.5	540*325*450
HGA9-1000KG	1	7/5	1.5	7.1*21	800	560	520	240	26	43	41	1.1	20	595*430*460
HGA9-2000KG	1	6	3.0	10*30	920	630	720	300	32	47	80	2.1	21	690*400*590



YT-SU D8+/ D8

DOUBLE BRAKE

ADVANTAGE

- High-strength nylon material chain guide
- Maintenance free overload clutch
- 5sprocket Lifting wheel improve chain wear & smooth lifting
- High-strength aluminum alloy fuselage shell
- Double AC Electromechanical Brake has been filed tested
- Class 6 Gearbox quiet and safe operation
- IP66, can work normally in the rain
- EN 818-7 standard G100 chain
- Class F Rugged and durable high-performance motor with overheat protection
- CE by TUV

YT-SU1 D8+

220V-440V 3 Phase Double Brake



The YT-SU D8+ Hoist meets all Standard requirements. The clutch, outside the load path, acts as a precise overload device; and safety factor is 10:1 with a double brake installed, The YT SU D8+ is in accordance with the VPLT Code of Practice.

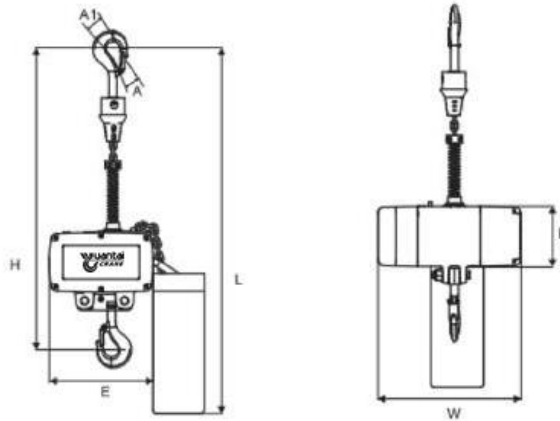

Specifications	
SWL acc. DGUV V54 (D8)	250Kg/500Kg/1000Kg
Power supply	220-440V 3Phase 50/60Hz
Cable	1m Cable with CEE-16/4
Chain	EN818-7
Dynamic safety factor for chain	min. 10:1
Grade of steel	100
Chain surface	galvanized
Chain Guide	Precise chain guide with 5-pocket chain wheel
Clutch	Patented friction clutch for overload protection
Full load noise level(db)	≤60
Brake	2 DC brake
Load hook	1-fall / tumble
Suspension	suspension hook
Mounting position	climbing & stationary
Plastic handles	without
Protection level	IP 66
Mechanism class /FEM9.511	1Bm/ 25% ED
Color	black, RAL9005 matt
DC Brake Size	10
DC Brake Operating Voltage	180VDC
DC Brake Rated Torque	16Nm
DC Brake gaps	0.2mm

Model	Capacity	Chain Fall	Speed (m/min)	Power (kw)	Chain (mm)	Hoist Dimension(mm)						No Chain Self Weight (kg)	Chain Weight (Kg/m)	Flight Case	
						L	W	H	D	A	A1			Weight(Kg)	Size(mm)
SU1-0.25	250KG	1	4	1.5	5*15	900	450	640	200	23	38	56	0.7	22	600*450*500
SU1-0.5	500KG	1	4/8	1.5	7.1*21	900	500	640	200	26	38	56	1.1	22	600*450*500
SU1-1.0-1	1000KG	1	4	2.2	9*27	990	500	630	200	32	48	65	1.9	22	680*450*650
SU1-1.0--2	1000KG	2	2/4	1.5	7.1*21	900	500	700	200	32	48	61	2.2	22	680*450*650

YT-SU2 D8+

220V 1 Phase Double Brake



The YT SU D8+ Hoist meets all Standard requirements. The clutch, outside the load path, acts as a precise overload device; and safety factor is 10:1 with a double brake installed, The YT SU D8+ is in accordance with the VPLT Code of Practice.

The YT-SU2 D8+ is single phase.

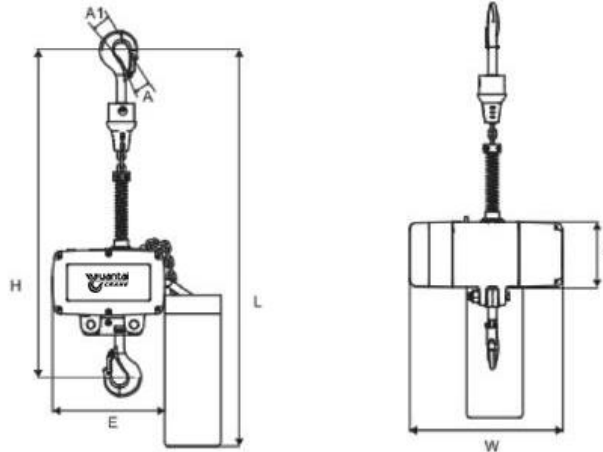

Specifications	
SWL acc. DGUV V54 (D8)	250Kg/500Kg/1000Kg
Power supply	220V 1Phase 50/60Hz
Cable	1m Cable with CEE-16/4
Chain	EN818-7
Dynamic safety factor for chain	min. 10:1
Grade of steel	100
Chain surface	galvanized
Chain Guide	Precise chain guide with 5-pocket chain wheel
Clutch	Patented friction clutch for overload protection
Full load noise level(db)	≤60
Brake	2 DC brake
Load hook	1-fall / tumble
Suspension	suspension hook
Mounting position	climbing & stationary
Plastic handles	without
Protection level	IP 66
Mechanism class /FEM9.511	1Bm/ 25% ED
Color	black, RAL9005 matt
DC Brake Size	10
DC Brake Operating Voltage	180VDC
DC Brake Rated Torque	16Nm
DC Brake gaps	0.2mm

Model	Capacity	Chain Fall	Speed (m/min)	Power (kw)	Chain (mm)	Hoist Dimension(mm)						No Chain Self Weight (kg)	Chain Weight (Kg/m)	Flight Case	
						L	W	H	D	A	A1			Weight(Kg)	Size(mm)
SU2-0.25	250KG	1	4	1.5	5*15	900	450	640	200	23	38	56	0.7	22	600*450*500
SU2-0.5	500KG	1	4/8	1.5	7.1*21	900	500	640	200	26	38	56	1.1	22	600*450*500
SU2-1.0-1	1000KG	1	4	2.2	9*27	990	500	630	200	32	48	65	1.9	22	680*450*650
SU2-1.0--2	1000KG	2	2/4	1.5	7.1*21	900	500	700	200	32	48	61	2.2	22	680*450*650

YT-SU3 BGV C1

220V-440V 3 Phase

The YT SU D8+ Hoist meets all Standard requirements. The clutch, outside the load path, acts as a precise overload device, and safety factor is 10:1 with a double brake installed, The YT SU D8+ is in accordance with the VPLT Code of Practice.

Low Voltage control.

Option: None noise bake.

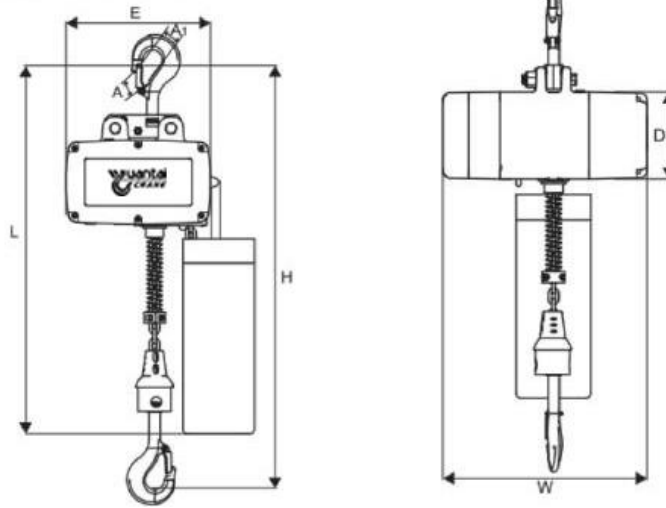

Specifications	
SWL acc. DGUV V54 (D8)	250Kg/500Kg/1000Kg
Power supply	220-440V 3Phase 50/60Hz
Cable	1m Cable with CEE-16/4
Chain	EN818-7
Dynamic safety factor for chain	min. 10:1
Grade of steel	100
Chain surface	galvanized
Chain Guide	Precise chain guide with 5-pocket chain wheel
Clutch	Patented friction clutch for overload protection
Full load noise level(db)	≤60
Brake	2 DC brake
Load hook	1-fall / tumble
Suspension	suspension hook
Mounting position	climbing & stationary
Plastic handles	without
Protection level	IP 66
Mechanism class /FEM9.511	1Am/ 25% ED
Color	black, RAL9005 matt
DC Brake Size	10
DC Brake Operating Voltage	180VDC
DC Brake Rated Torque	16Nm
DC Brake gaps	0.2mm

Model	Capacity	Chain Fall	Speed (m/min)	Power (kw)	Chain (mm)	Hoist Dimension(mm)							No Chain Self Weight (kg)	Chain Weight (Kg/m)	Flight Case	
						L	W	H	D	E	A	A1			Weight(Kg)	Size(mm)
SU3-G0.25	250KG	1	4	1.5	5*15	900	500	640	200	330	23	38	56	0.7	22	600*450*500
SU3-G0.5	500KG	1	4/8	1.9	7.1*21	900	500	640	200	330	26	38	56	1.1	22	600*450*500
SU3-G1.0-1	1000KG	1	4	2.2	9*27	990	500	630	200	330	-	48	65	1.9	22	680*450*650
SU3-G1.0--2	1000KG	2	2/4	1.9	7.1*21	900	500	700	200	330	-	48	61	2.2	22	680*450*650

YT-SU4 D8

220V-440V 3 Phase

Light weight, quiet and portable, the YT SU is designed and built for the unique rigging needs encountered at small venues. Featuring an overload device that protects the hoist, operator, and structure from damaging overloads.

[Option](#)

[Double Brake / Customized logo](#)

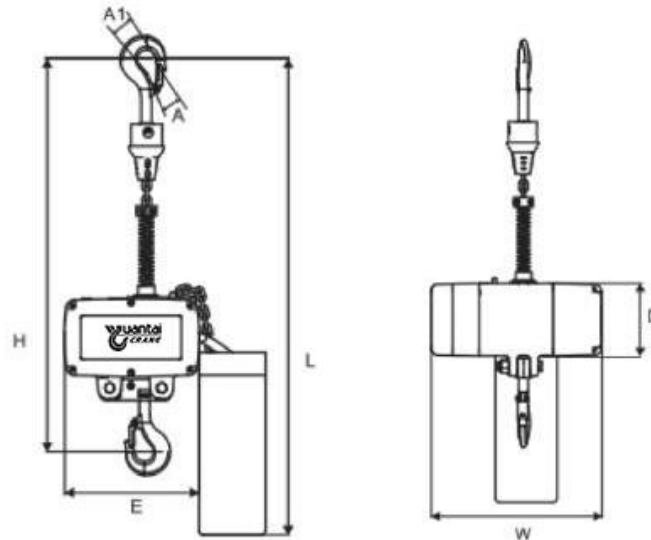

Specifications	
SWL acc. DGUV V54 (D8)	500Kg/1000Kg/2000Kg
Power supply	220-440V 3Phase 50/60Hz
Cable	1m Cable with CEE-16/4
Chain	EN818-7
Dynamic safety factor for chain	min. 8:1
Grade of steel	100
Chain surface	galvanized
Chain Guide	Precise chain guide with 5-pocket chain wheel
Clutch	Patented friction clutch for overload protection
Full load noise level(db)	≤60
Brake	1 DC brake
Load hook	1-fall / tumble
Suspension	suspension hook
Mounting position	climbing & stationary
Plastic handles	without
Protection level	IP 66
Mechanism class /FEM9.511	1Am/ 25% ED
Color	black, RAL9005 matt
DC Brake Size	10
DC Brake Operating Voltage	180VDC
DC Brake Rated Torque	16Nm
DC Brake gaps	0.2mm

Model	Capacity	Chain Fall	Speed (m/min)	Power (kw)	Chain (mm)	Hoist Dimension(mm)						No Chain Self Weight (kg)	Chain Weight (Kg/m)	Flight Case	
						L	W	H	D	A	A1			Weight(Kg)	Size(mm)
SU4-0.5	500KG	1	4	1.5	5*15	820	365	400	200	23	32	38	0.7	19.5	500*550*500
SU4-1.0	1000KG	1	4/8	1.5	7.1*21	820	365	480	200	26	38	40	1.1	19.5	500*550*500
SU4-2.0-1	2000KG	1	4	2.2	9*27	960	500	630	200	32	47	52	1.7	19.5	520*570*500
SU4-2.0--2	2000KG	2	2/4	1.5	7.1*21	820	365	680	200	32	47	45	2.2	19.5	520*570*500



Yuantai Crane Machinery

Crane&Hoist Solution Supplier

Address

3#-A-2005, Shenglong Plaza, Zhengzhou City, Henan
Province, China.

Tel

0086-371-65760776

Fax

0086-371-65760775

Email

yuntai@ytcrane.com

Website

www.ytcrane.com

